



www.gillathletics.com
800-637-3090

851A, 852A, 852P - INTERNATIONAL TRACK CURBING SPECIFICATIONS

The International Track Curbing is manufactured from 6063 structural aluminum extruded and hardened to a T6 condition. The curb is custom rolled to match the curve of your track. All we require is the track "Measure Line" radius. When curbing is to be used, the inside lane line is 11 13/16" (30 cm) inside the measure line. Each 20' curved piece is labeled with a "B", "C", or "D" to indicate where it goes on the track (not all tracks will require 3 different curves and straights are not labeled). Track curbing orders also come with a sheet of labels to number your track curbing for easier re-installation if it is stored when not in use.

851A	Curbing	(Plain aluminum finish)
852A	Anodized Curbing	(Silver or Gold)
852P	Powder Coated Curbing	(White, Silver, Gray, Black, Navy Blue, Royal Blue, Light Blue, Dark Green, Kelly Green, Yellow Gold, Old Gold, Orange, Red, Maroon, or Purple)





www.gillathletics.com
800-637-3090

851A, 852A, 852P - INTERNATIONAL TRACK CURBING INSTRUCTIONS

The 851A International Track Curbing is manufactured from 6063 structural aluminum extruded and hardened to a T6 condition. The curb is custom rolled to match the curve of your track and sits at a height of 2" (5 cm). Joint sleeves are riveted into one end of each curb section. The corresponding ends are milled for a drop in place fit. Curbing is shipped with the support clips installed. Four inch anchor pins are available where required to help anchor curb to the track. These are easily installed in the field where needed. All we require is the track "Measure Line" radius. When curbing is to be used, the inside lane line is 11 13/16" (30 cm) inside the measure line. Measurements in brackets are in centimeters.

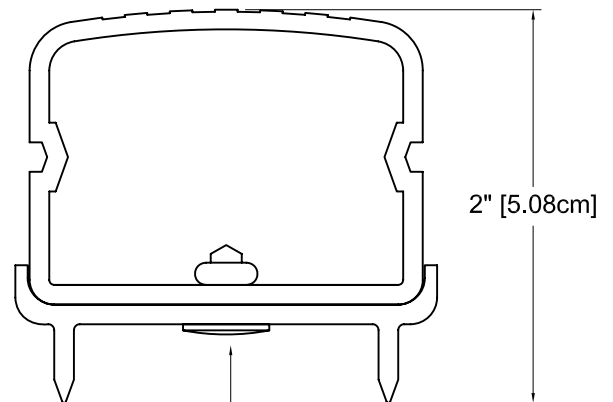
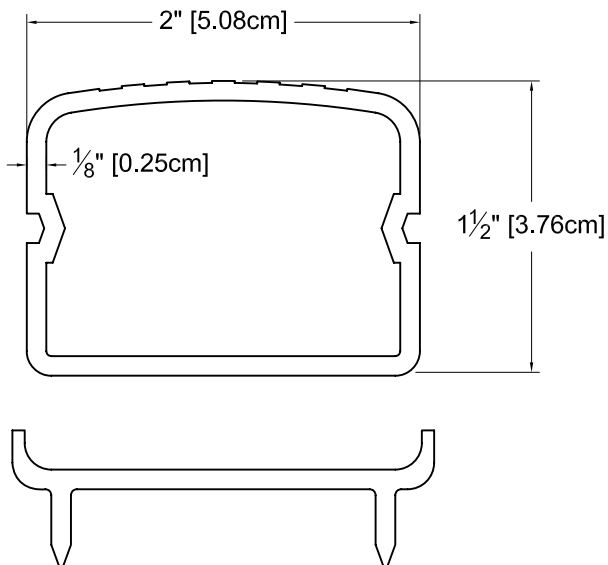
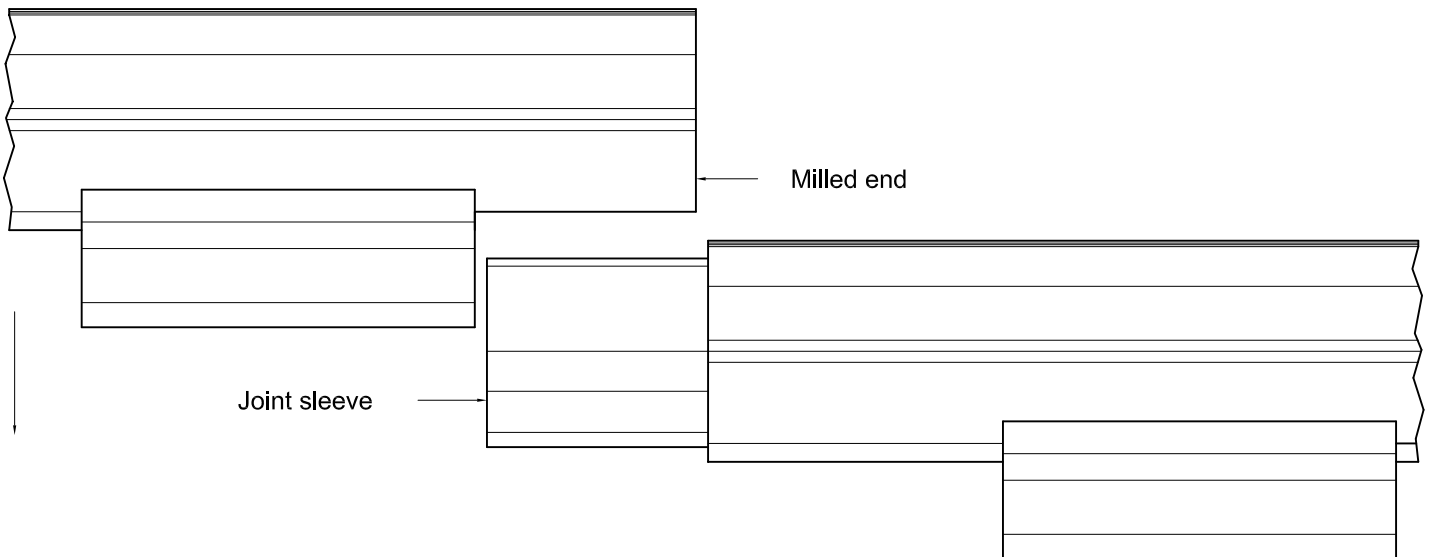

Support clips are pre installed with aluminum pop rivets.

TRACK CURBING PLAN EXAMPLE

(Plan is dependent upon track dimensions, metric dimensions are available)

When laying out the curb, start where the curve of the track transitions into the straight, as shown above. Layout full, 20ft, length straight sections, with the notched ends overlapping the joint sleeve of the previous piece. Lay the curbing directly over the 2" white painted line. Depending on the temperature at the time of installation, leave a gap to allow for thermal expansion of the aluminum. At the end of the straight section of track there will be distance shorter than 20ft; lay a full length piece down and mark it where it crosses the transition point. Cut the piece to fit. The drop of the cut should be toward the milled end of the curbing. Start laying out the full, 20ft, length curved sections on the painted line going around the bend of the track. Again, there will be a place directly before the transition from curve to straight, where a full length curve section will not fit. Lay a full length curved piece down, mark it where it crosses the transition point, and cut it down to fit the space. Begin the second straight away the same as before and finish with the other bend of the track. Some tracks will require special breaks in the curbing so that it can be removed during events such as the javelin throw or water jump steeple chase. These breaks are usually accomplished through multiple special short sections and care must be taken when planning these. It may be beneficial to layout all the curbing around the entire track before cutting any pieces down to short sections.

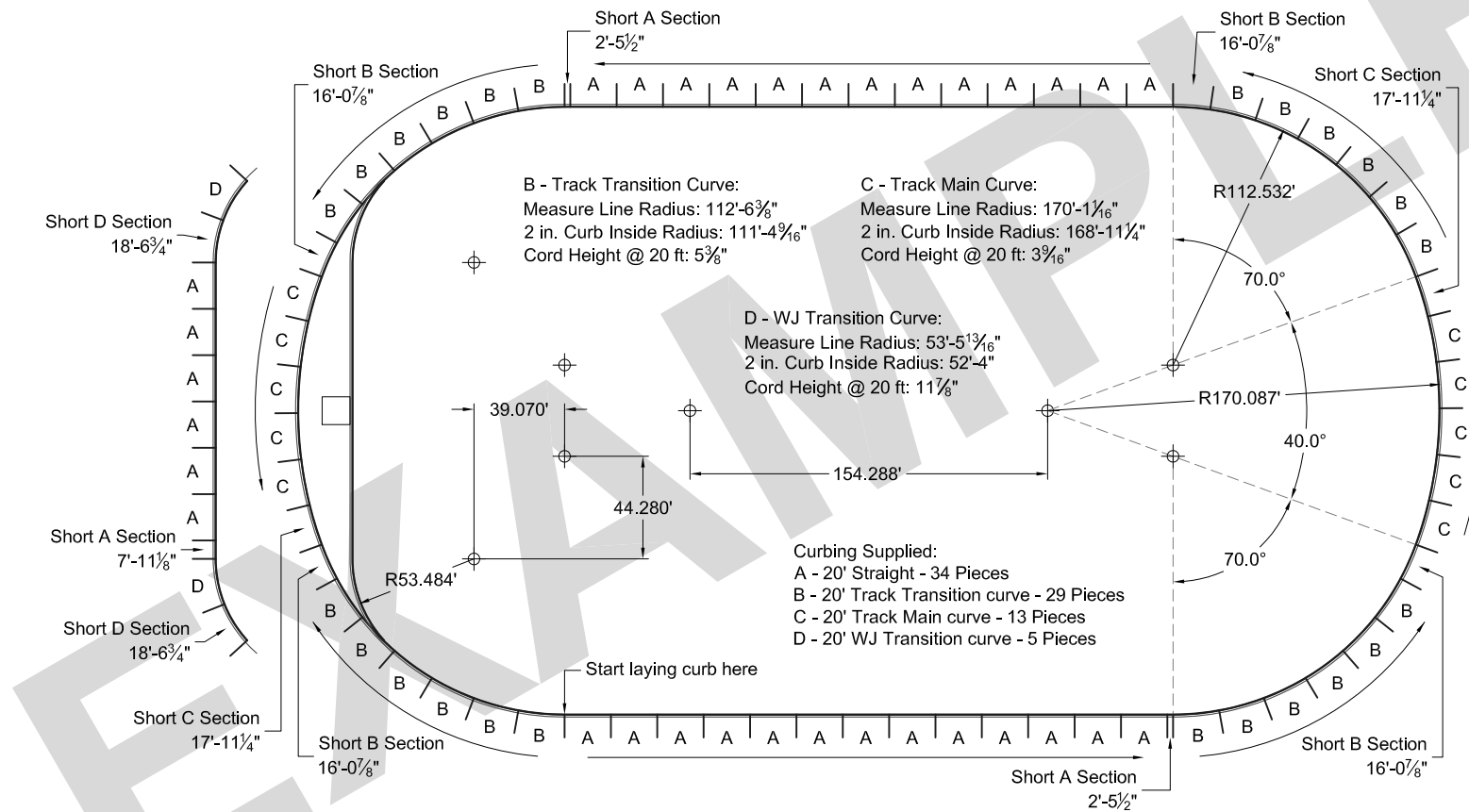

Note: Short curb sections are cut in the field from full length pieces. Lengths of short sections are approximate, actual length will need to be measured during installation prior to cutting the short sections. Notched ends are not required on short sections. To allow for curb expansion on hot days, 1/16" to 1/8" gaps should be left between each curb section. The temperature of the curb during installation should be taken into account when setting the gaps.



www.gillathletics.com
800-637-3090

851A, 852A, 852P - INTERNATIONAL TRACK CURBING INSTRUCTIONS

Thermal Expansion Table

Highest curb temp expected minus curb temp at installation (Fahrenheit)	Expansion of a 20ft length of alum curb (in)	Expansion of a 20ft length of alum curb (mm)	Recommended gap when installing curb (in)	Recommended gap when installing curb (mm)
0	0.0000	0.00	1/16	1.6
10	0.0298	0.76	1/16	2.3
20	0.0595	1.51	1/8	3.1
30	0.0893	2.27	1/8	3.9
40	0.1190	3.02	3/16	4.6
50	0.1488	3.78	3/16	5.4
60	0.1786	4.54	1/4	6.1
70	0.2083	5.29	1/4	6.9
80	0.2381	6.05	5/16	7.6
90	0.2678	6.80	5/16	8.4
100	0.2976	7.56	3/8	9.1

Example:

You are installing the curbing on the track in the spring and the temperature outside that day is 50°F. The record high temperature for where you are is 100°F.

$$100^{\circ} - 50^{\circ} = 50^{\circ}\text{F}$$

Each '20ft' section of aluminum curbing will expand approximately 0.1488" from its current length (which is probably not exactly 20ft due to temperature) when the temperature reaches 100°F.

Leaving $\frac{3}{16}$ " between each curb section will give the curbing enough room to expand on hot days and keep the curb from buckling,

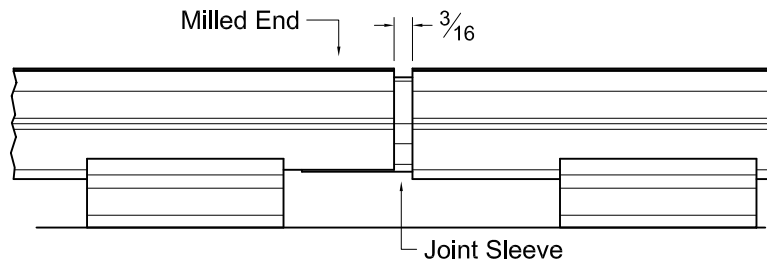



www.gillathletics.com
800-637-3090

851A, 852A, 852P - INTERNATIONAL TRACK CURBING DIMENSION CERTIFICATION FORM

Use this form to record the dimensions of the track for which a curbing order is requested. Dimensions should be recorded as accurately as possible, to the nearest 1/8". This form is only for single radius bend tracks. If the track has multiple radius bends and/or water jump curbing, then we will need detailed drawings of the track layout.

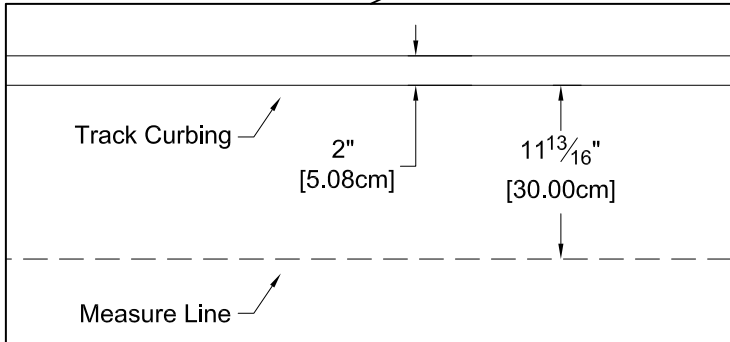
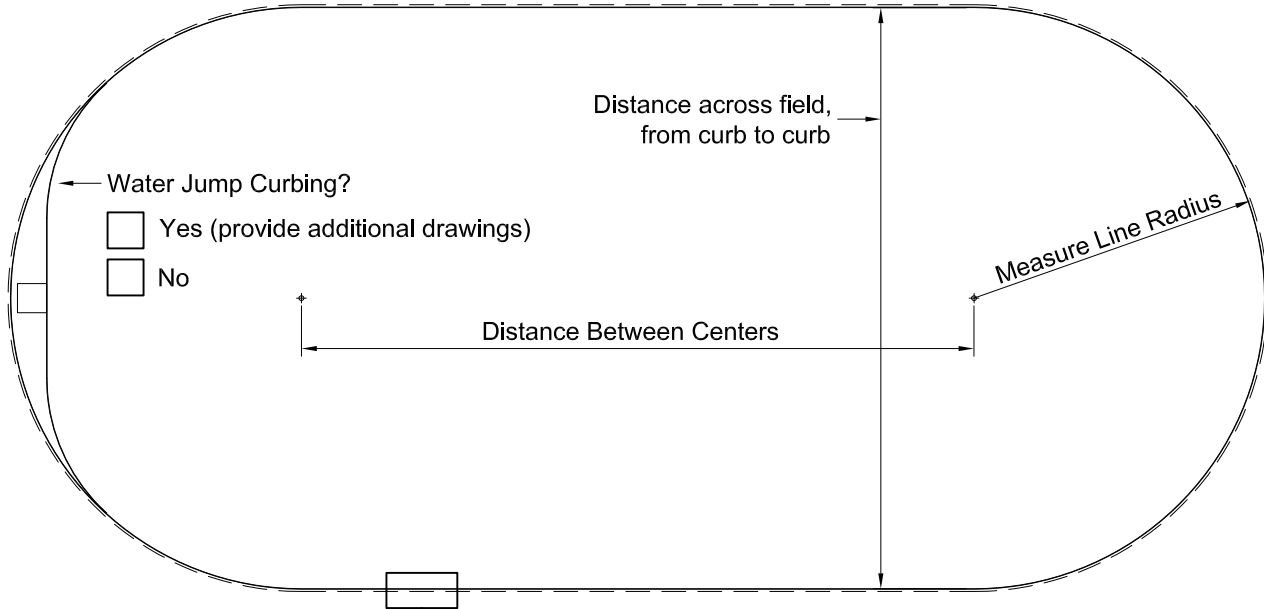

Required Dimensions:

One of the following

<input type="text"/>	Measure Line Radius
<input type="text"/>	Distance across field, from curb to curb

One of the following

<input type="text"/>	Distance between centers
<input type="text"/>	Perimeter at the Measure Line
<input type="text"/>	Perimeter at curbing

Curbing Style:

Check one of the following

851A - Curbing, Plain Aluminum

852A - Anodized Curbing

852P - Powder Coated Curbing

Certification:

Signature and Date: _____

Name and title of authorizing official: _____

Project Name / Order #:



www.gillathletics.com
800-637-3090

851A, 852A, 852P - INTERNATIONAL TRACK CURBING INSTRUCTIONS

When installing track curbing, you will need to make field cuts in several places such as where the straight sections and curve sections meet.

It is recommended that when cutting short sections, you measure from the notched end and drop the sleeved end.

Then install a new sleeve and support bracket using a pop-rivet or sheet metal screw (not provided). Extra sleeves and support brackets are provided. Call Gill if more are needed.

You may also need to notch an end in the field. Use a small hack saw to cut the notch out.

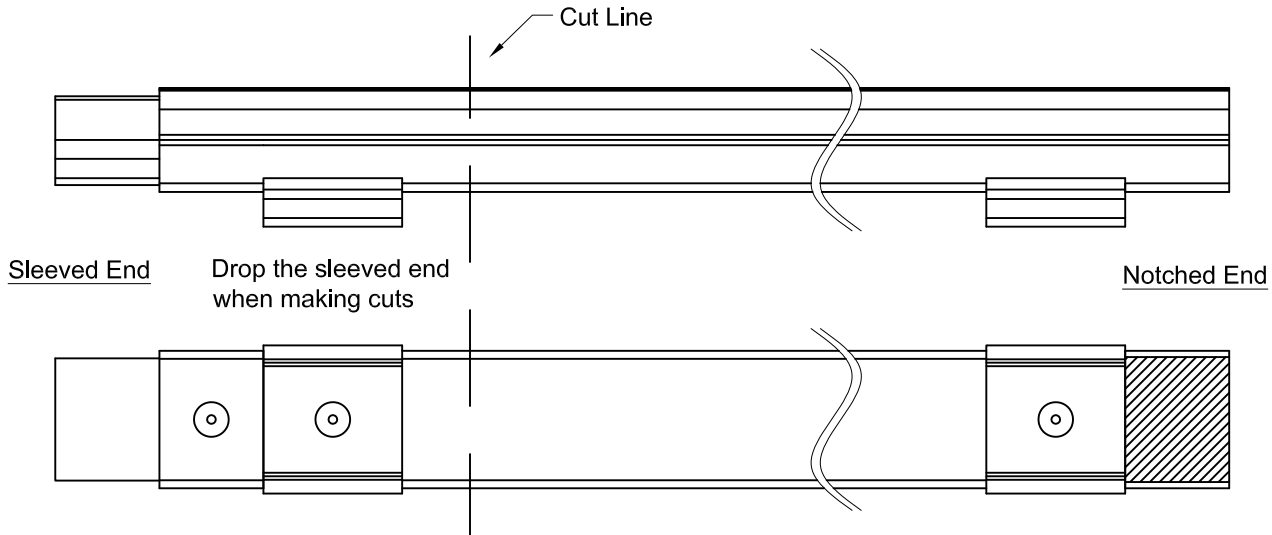
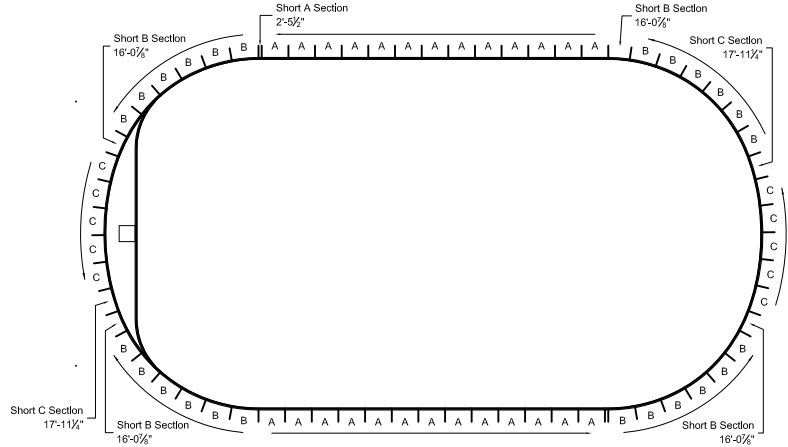

Insert new sleeve (M9991) 1 1/2" into the curbing extrusion and fasten in place with a pop-rivet.

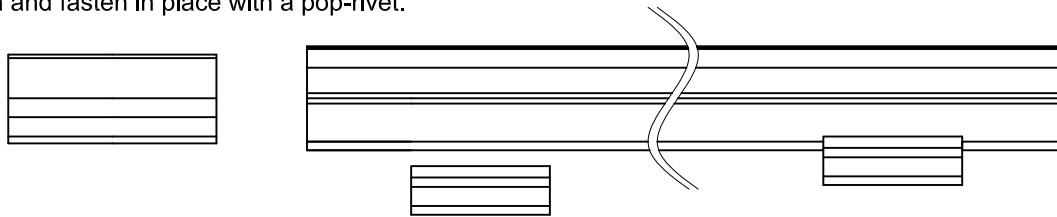

Install new support clip (M9992) 1 1/2" in from the end and fasten it in place with a pop-rivet.

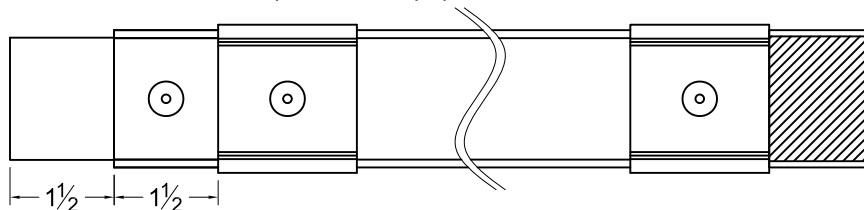

THIS WARNING IS GIVEN IN COMPLIANCE WITH CALIFORNIA'S PROPOSITION 65:
WARNING
This product contains chemicals known to the State of California to cause cancer, birth defects or other reproductive harm.