

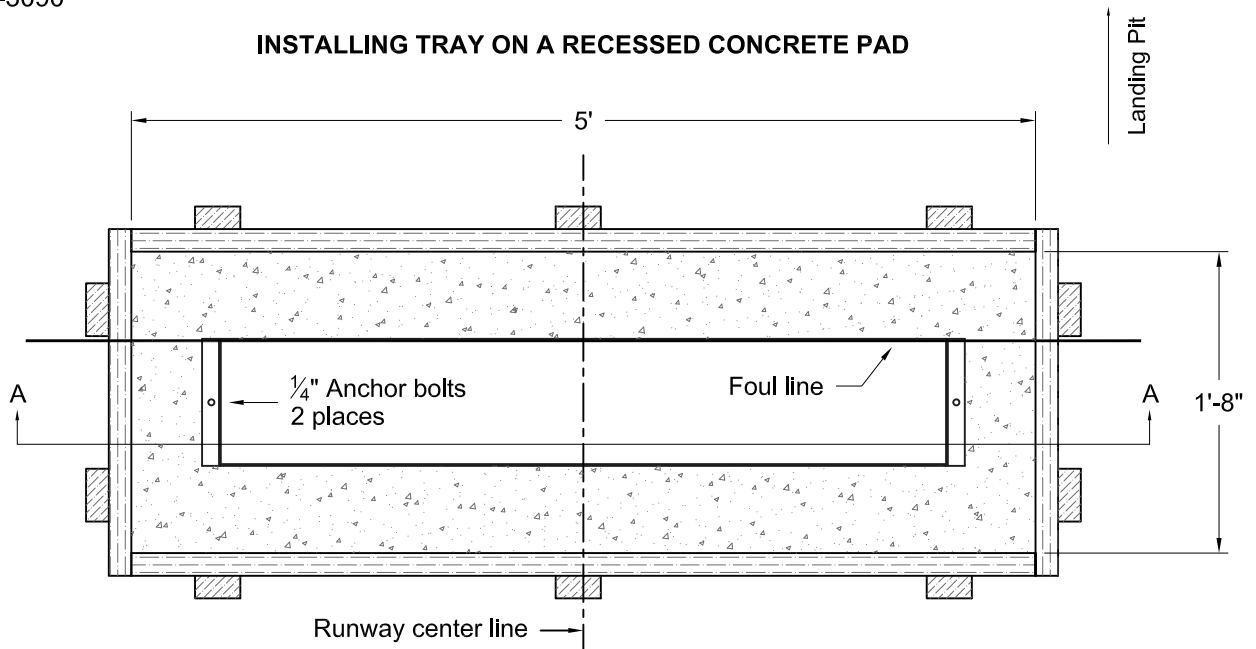

www.gillathletics.com
800-637-3090

443 - 8" TAKE-OFF BOARD TRAY INSTALLATION INSTRUCTIONS



When positioning tray on base concrete, insure tray sits flat and does not warp when anchored in place. The tray lid should not rock if tray is properly installed. When finishing runway subsurface around the sides of the tray, insure the procedure does not deform the tray sides inward.

The width of the tray must remain 8 ³/₁₆" or the lids will not fit with the proper clearance.

NOTE: It is recommended that a drain be installed in the box by drilling a hole in the box to match a PVC pipe drain line through the base concrete. This line can go to a drainage system or a gravel sump. See the Take Off Board Drainage page.

NOTE: The surface elevation of the finished runway includes the actual thickness of the artificial runway surface to be applied to the concrete or asphalt runway.

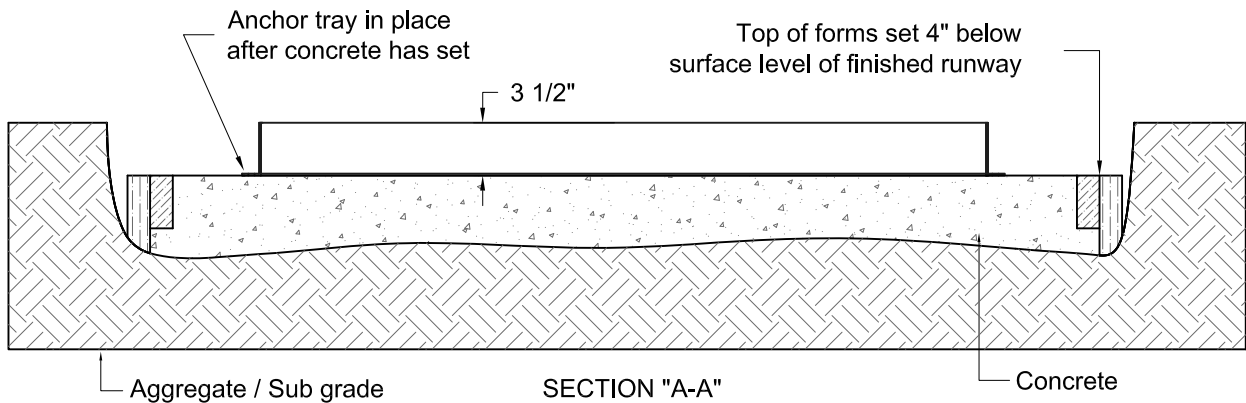

NOTICE: All installations should be done by experienced contractors and in accord with all applicable codes, laws and regulations. Suggested installation instructions herein are illustrative only and should be adapted to suit local requirements. Gill Athletics is not responsible for the manner in which these products are installed.



www.gillathletics.com
800-637-3090

443 - 8" TAKE-OFF BOARD TRAY INSTALLATION INSTRUCTIONS

FINISHING INSTALLATION

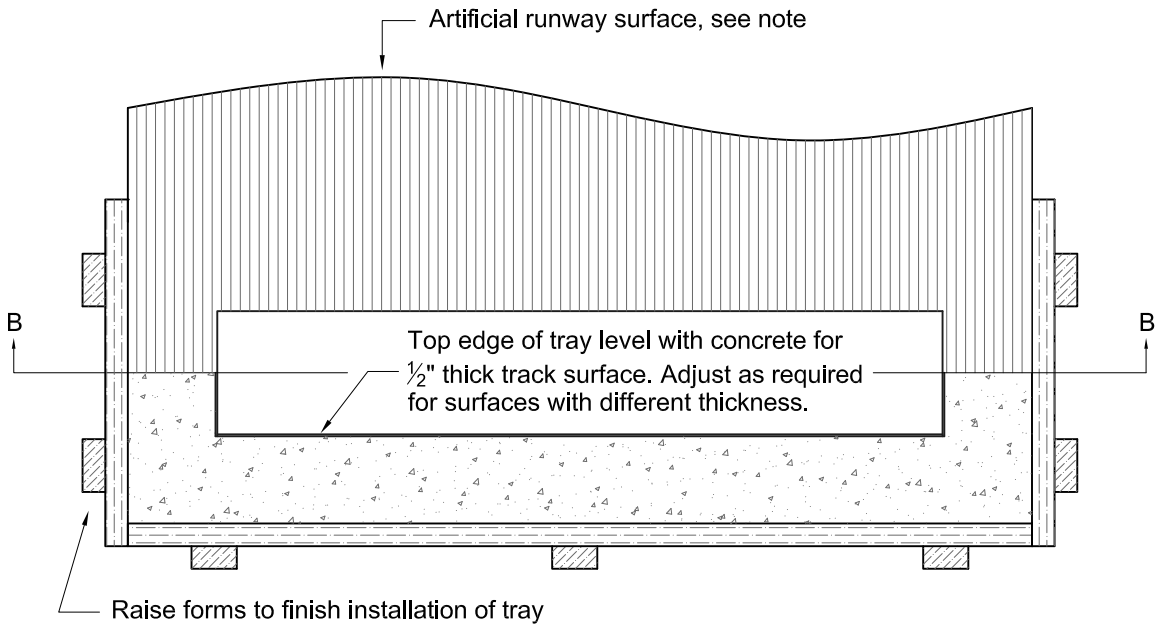

NOTE:

1. Artificial runway surface should be trimmed even with the inside edge of the tray.
2. If tray is installed in an asphalt runway without an artificial surface, the top edge of the tray should be $\frac{1}{2}$ " below the asphalt runway.

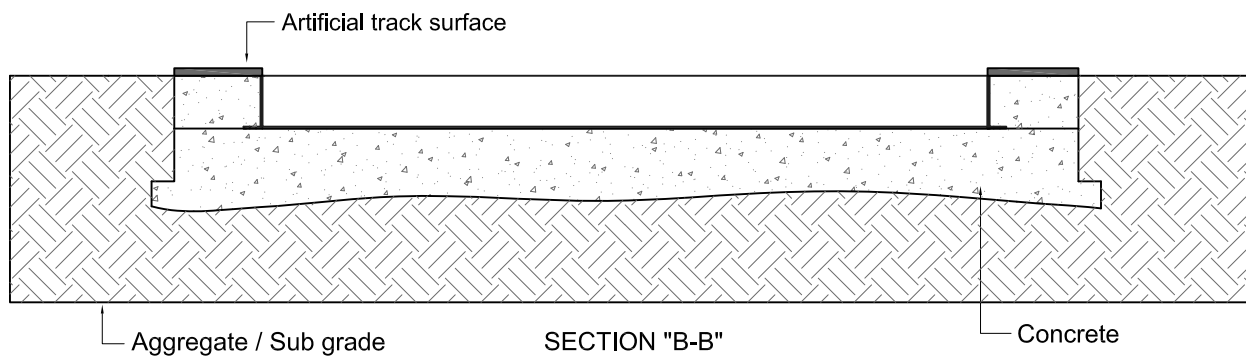

THIS WARNING IS GIVEN IN COMPLIANCE
WITH CALIFORNIA'S PROPOSITION 65:

WARNING

This product contains chemicals known to the
State of California to cause cancer, birth defects
or other reproductive harm.



www.gillathletics.com
800-637-3090

443 - 8" TAKE-OFF BOARD TRAY INSTALLATION INSTRUCTIONS

TAKE OFF BOARD LOCATION

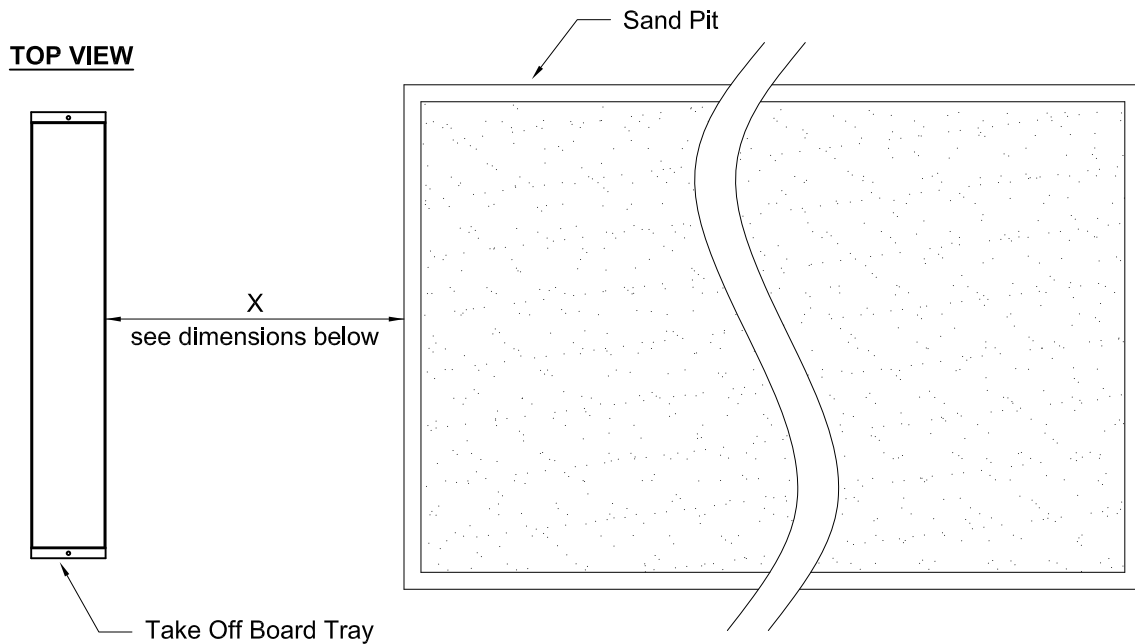

Long Jump

NFHS:

High School Girls: 8'
High School Boys: 12'

Note from NFHS:

Distance from foul line or take off board may be adjusted to accommodate different levels of competition or sand pit dimensions.

NCAA and IAAF:

In the Long Jump, the distance between the takeoff board and the nearer edge of the landing area shall be at least 1 meter and not more than 3 meters. The distance between the foul line and the farther edge of the landing area shall be at least 10 meters.

Triple Jump

NFHS:

High School Girls: 24'
High School Boys: 32'

Note from NFHS:

Distance from foul line or take off board may be adjusted to accommodate different levels of competition or sand pit dimensions.

NCAA:

In the Triple Jump, the nearer edge of the landing area shall be at least 11 meters from the foul line for men and 8.5 meters for women. Distances of 12.5 meters and 11 meters, respectively, are recommended.

IAAF:

The distance between the take-off line for men and the far end of the landing area shall be at least 21m. For international Competitions, there should be a separate take-off board for men and women. The take-off line shall not be less than 13m for men and 11m for women from the nearer end of the landing area. For any other competition, this distance shall be appropriate for the level of competition.



www.gillathletics.com
800-637-3090

LJ & TJ TAKE-OFF BOARD TRAYS DRAINAGE

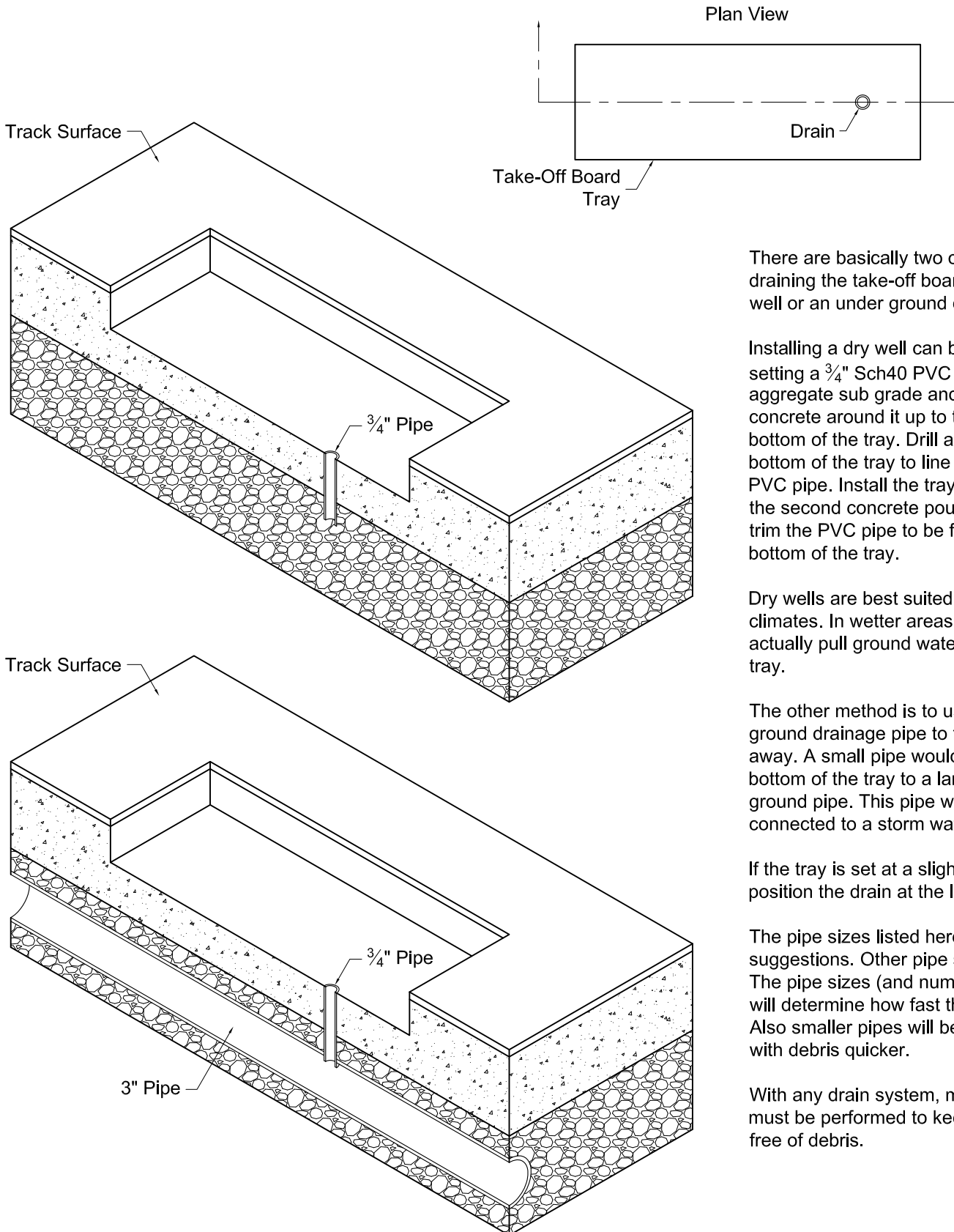

There are basically two options for draining the take-off board tray; a dry well or an under ground drainage pipe.

Installing a dry well can be as simple as setting a $\frac{3}{4}$ " Sch40 PVC pipe in the aggregate sub grade and pouring concrete around it up to the level of the bottom of the tray. Drill a hole in the bottom of the tray to line up with the PVC pipe. Install the tray and complete the second concrete pour. If need be, trim the PVC pipe to be flush with the bottom of the tray.

Dry wells are best suited for dry climates. In wetter areas a dry well may actually pull ground water up into the tray.

The other method is to use an under ground drainage pipe to take the water away. A small pipe would lead from the bottom of the tray to a larger under ground pipe. This pipe would be connected to a storm water system.

If the tray is set at a slight inclination, position the drain at the low end.

The pipe sizes listed here are just suggestions. Other pipe sizes will work. The pipe sizes (and number of drains) will determine how fast the tray drains. Also smaller pipes will become clogged with debris quicker.

With any drain system, maintenance must be performed to keep the drains free of debris.



Trubolt Wedge Anchor

INSTALLATION INSTRUCTIONS

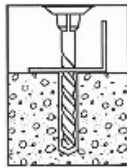

1. Using a bit whose diameter equals the anchor diameter, drill hole to any depth exceeding the minimum embedment. Clean hole.



2. Assemble anchor with nut and washer so that the top of the nut is flush with the top of the anchor. Drive anchor through material to be fastened so that nut and washer are flush with surface material.

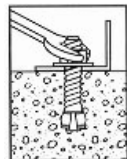

3. Expand anchor by tightening nut 3 to 5 turns, or to the specific torque requirement (see selection chart).